

**SEEPZ SPECIAL ECONOMIC ZONE  
ANDHERI (EAST), MUMBAI.**

.....

**AGENDA FOR**

**MEETING OF THE APPROVAL COMMITTEE FOR SECTOR SPECIFIC SPECIAL ECONOMIC ZONE FOR IT/ITES AT KALWA TRANS THANE CREEK INDUSTRIAL AREA, MIDC, DISTRICT THANE OF M/S. MINDSPACE BUSINESS PARKS PVT. LTD. PREVIOUSLY KNOWN AS M/S. SERENE PROPERTIES PVT. LTD.-SEZ.**

**VENUE : Conference Hall, BFC Building, 2<sup>nd</sup> Floor, Behind The Office Of Development Commissioner, SEEPZ-SEZ, Andheri (East), Mumbai- 400 096.**

**DATE : 27.10.2017.**

**TIME : 12.00 PM Onwards**

**MEETING OF THE APPROVAL COMMITTEE FOR SECTOR SPECIFIC SPECIAL ECONOMIC ZONE FOR IT/ITES AT KALWA TRANS THANE CREEK INDUSTRIAL AREA, MIDC, DISTRICT THANE OF M/S. MINDSPACE BUSINESS PARKS PVT. LTD. PREVIOUSLY KNOWN AS M/S. SERENE PROPERTIES PVT. LTD.-SEZ.**

**INDEX**

<b>Agenda Item No.</b>	<b>Subject</b>
<b>Agenda item No. 01 :-</b>	Confirmation of minutes of the meeting held on 18.08.2017.
<b>Agenda item No. 02 :-</b>	Approval for creation and sharing of common infrastructure facilities-M/s. Here Solutions India Pvt.Ltd.

Minutes of the 63<sup>rd</sup> Meeting of the Approval Committee held under the Chairmanship of Development Commissioner for Sector Specific Special Economic Zone for IT/ITES at Navi Mumbai, District Thane of M/s. Mindspace Business Parks Pvt.Ltd previously known as Serene Properties Pvt. Ltd held on 18.08.2017.

- 
- |                    |   |   |
|--------------------|---|---|
| 1. Name of the SEZ | : | M/s.Mindspace Business Parks Private Limited. |
| 2. Sector          | : | IT/ITES.                                      |
| 3. Meeting no      | : | 63  |
| 4. Date            | : | 18.08.2017                                    |

**Members Present :**

- |  |   |   |
|--|---|---|
| 1. Shri V.P. Shukla<br>Jt. Development Commissioner<br>SEEPZ-SEZ | : | Member.   |
| 2. Smt. S. R. Motwani<br>Dy. Director                            | : | Nominee of the Zonal addl.<br>DGFT, Mumbai.                   |
| 3. Smt. S.P. Magar<br>Dy. Director                               | : | Nominee of the office of Jt. Director of<br>Industries (MMR). |
| 4. Shri.S.H Padwal<br>Sub Regional Officer                       | : | Nominee of the MPCB.  |
| 5. Shri. Sunil Bhatt<br>Dy. Commissioner IT                      | : | Nominee of the Income Tax (HQ)                                |
| 6. Shri. B. Timothy<br>Addl. Commissioner                        | : | Nominee of the Belapur CGST<br>Committee.                     |

**Special Invitee:**

- |                        |   |  |
|------------------------|---|--|
| 7. Shri Pravin Chandra | : | Jt. Development Commissioner<br>SEEPZ-SEZ            |
| 8. Shri. S.K. Shukla   | : | Specified Officer, Mindspace-SEZ.                    |
| 9. Smt. Priti Yadav    | : | D.G.M, M/s. Mindspace Business<br>Parks Pvt.Ltd-SEZ. |

**Agenda Item No.01 : Confirmation of Minutes of the meeting held on 11.07.2017.**

-----

The Minutes of the 62<sup>th</sup> Meeting held on 11.07.2017 were confirmed.

**Agenda Item No. 02:-Monitoring Performance of unit M/s. MModal Global Services Pvt.Ltd.**

After deliberation, the Committee noted the performance on Monitoring for the years 2015-16 and 2016-17 of the unit.

The unit has submitted Annual Performance Report for the years 2015-16 and 2016-17 duly certified by the Chartered Accountant. The performance of the unit has been monitored upto 2015-16 and 2016-17 on cumulative basis.

The unit has achieved positive NFE i.e. **Rs.7876.84 lakhs** on cumulative basis during the years 2015-16 and 2016-17.

The meeting ended with a vote of thanks to the Chair.



**Chairperson - cum -  
Development Commissioner**

**GOVERNMENT OF INDIA  
OFFICE OF THE DEVELOPMENT COMMISSIONER,  
SEEPZ SPECIAL ECONOMIC ZONE,  
ANDHERI (EAST), MUMBAI**

\*\*\*\*\*

**AGENDA NOTE FOR CONSIDERATION OF UNIT APPROVAL COMMITTEE**

-----

**a) Proposal: -**

Application for creation and sharing of common infrastructure facilities among their 5 SEZ units of **-M/s. Here Solutions India Pvt.Ltd.**

**b) Specific Issue on which decision of UAC is required:**

Approval for creation and sharing of common infrastructure facilities among their 5 SEZ units.

**c) Relevant provision of SEZ Act, 2005 & Rules, 2006/  
Instruction/Notification:**

According to Rules 27 (5) "A Unit may import or procure from Domestic Tariff Area, all types of goods and services, without payment of duty, taxes of cess fro creating a central facility for use by Units in Special Economic Zone and where such facility is created for software development, the same may also be accessed by software exporters of Domestic Tariff Area".

**d) Other Information: -**

The unit wish to create and share common infrastructure facilities created by IPC 3 location i.e. Network and its equipment as listed below with their other SEZ units i.e. IPC1, IPC2, IPC 4, IPC 5 in accordance to the provision of 27 (5) of SEZ Rule 2006:

**Contd...2/-**

: 2 :

S.No.	Name of Infrastructure facility which will be shared
1	Routers
2	Networking Equipments
3	Internet lines/private circuits for receiving/ transmitting data to International Circuits

Details of Address and LOA of the units are as follows:-

S.No	Nomenclature of the Unit	LOA No & Date	Address
1	IPC 1	SEEPZ-SEZ/IA-I/APL/SW-01/2008-09/5761 dt: 07.08.2008	Unit No. 305-308, 3 <sup>rd</sup> Floor, Multistoried Bldg. SEEPZ-SEZ, MIDC, Andheri-East, Mumbai-400096
2	IPC 2	SEEPZ/NEWSEZ/SERENE-THANE/12/2010-11/4636 dt 31.03.2011	Unit no. 1, 5 <sup>th</sup> office level, Bldg. No. 5 & 6, Mindspace Business Park Pvt. Ltd.-SEZ, Thane Belapur Road, Airoli, Navi Mumbai-400708
3	IPC 3	SEEPZ/NEWSEZ/SERENE-THANE/43/2014-15/9592 dt 24.07.2014	Unit no. 1, 3 <sup>rd</sup> office level, Bldg. No. 5 & 6, Mindspace Business Park Pvt. Ltd.-SEZ, Thane Belapur Road, Airoli, Navi Mumbai-400708
4	IPC 4	SEEPZ/NEW-SEZ/Gigaplex-Thane/HSIPL/05/2015-16/06471, dt.21.04.2016	3 <sup>rd</sup> Floor, Bldg. No. 2, IT Plot No-5, Gigaplex Estate Pvt. Ltd.-SEZ, Thane Belapur Road, Airoli, Navi Mumbai-400708
5	IPC 5	SEEPZ/NEW-SEZ/Gigaplex-Thane/HSIPL/09/2016-17/04356, dt.23.01.2017	4 <sup>th</sup> Floor, Bldg. No. 2, IT Plot No. 5, Gigaplex Estate Pvt. Ltd.-SEZ, Thane Belapur Road, Airoli, Navi Mumbai-400708

Further, the unit has stated in their application that entire cost of creating common infrastructure facility will be incurred by IPC-3 and has been recorded in the books of IPC-3 only.

A copy of letter dated **13.07.2017 & 23.10.2017** is enclosed.

The proposal of the unit is placed before the Approval Committee for consideration.

\*\*\*\*\*

340  
here

October 23, 2017

To,  
The Development Commissioner  
SEEPZ Special Economic Zone  
Andheri (E), Mumbai - 400096

=====  
**Subject:** In continuation of our Application for approval w.r.t. creation of common infrastructure facilities and sharing of the same with our 4 another SEZ units located within your jurisdiction at SEEPZ-SEZ, Mindspace Business Park-SEZ and Gigaplex-SEZ in accordance with the provisions of Rule 27 (5) of SEZ Rules, 2006 along with creation of Disaster recovery and BCP Centre outside SEZ for routing Secondary Communication Network in the event of any disaster/failure.  
=====

=====  
**Ref:** Letter of Approval No. SEEPZ/NEW-SEZ/SERENE-THANE/43/2014-15/9592 Dated: 24.07.2014 (For Unit located at Unit No. 1, 3<sup>rd</sup> Office Level, Building No. 5 & 6, Mindspace Business Park Pvt. Ltd.-SEZ (Formerly known as Serene Properties Pvt. Ltd.-SEZ), Mindspace, Thane-Belapur Road, Airoli, Navi Mumbai-400708)  
=====

Dear Sir,

With reference to the above, we would like to indicate here that we had submitted an application for following approvals to your good office vide our application dated: 13.06.2017

1. Creation and Sharing of common infrastructure facilities created by **IPC 3** location i.e. Network and its equipment as listed below with **other SEZ Units of ours i.e. IPC 1, IPC 2, IPC 4, IPC 5 in accordance to the provisions of Rule 27 (5) of SEZ Rules, 2006;**

S.No	Name of Infrastructure facility which will be shared
1	Routers
2	Networking Equipment's
3	Internet Lines/Private Circuits for receiving/transmitting data to International Circuits

2. Creation of Disaster Recovery/BCP Center for terminating secondary circuits for data communication purpose which will be used in the event of failure of Primary circuits and thereby pushing data from such DR/BCP Center to a location outside India in accordance to the **Guidelines Prescribed by Ministry of Commerce and Industry for setting up DR/BCP Centers vide its letter No. D.12/25/2012-SEZ Dated: 22.02.2013.**



27745  
24/10/17

339  
here

However, we are awaiting approval on both of the above proposals. Therefore, we hereby would like to request your good office to grant us approval at the earliest so that we can complete necessary compliances as per SEZ Act and Rules.

Should you require, any other information please feel free to revert to us.

Thanking you

For **HERE Solutions India Pvt. Ltd.- IPC 3**

  
  
Authorized Signatory



Req. 10 - 421700126455 330

here

June 13, 2017

To,  
The Development Commissioner  
SEEPZ Special Economic Zone  
Andheri (E), Mumbai - 400096

=====  
**Subject:** Application for approval w.r.t. creation of common infrastructure facilities and sharing of the same with our 4 another SEZ units located within your jurisdiction at SEEPZ-SEZ, Mindspace Business Park-SEZ and Gigaplex-SEZ in accordance with the provisions of Rule 27 (5) of SEZ Rules, 2006 along with creation of Disaster recovery and BCP Centre outside SEZ for routing Secondary Communication Network in the event of any disaster/failure.

-----  
**Ref:** Letter of Approval No. SEEPZ/NEW-SEZ/SERENE-THANE/43/2014-15/9592 Dated: 24.07.2014 (For Unit located at Unit No. 1, 3<sup>rd</sup> Office Level, Building No. 5 & 6, Mindspace Business Park Pvt. Ltd.-SEZ (Formerly known as Serene Properties Pvt. Ltd.-SEZ), Mindspace, Thane-Belapur Road, Airoli, Navi Mumbai-400708)  
=====

Dear Sir,

**Background:**

With reference to the above, we would like to intimate this office that, we **HERE Solutions India Pvt. Ltd. (Hereinafter referred to as IPC 3)** is an approved SEZ Unit located at **Unit No. 1, 3<sup>rd</sup> Office Level, Building No. 5 & 6, Mindspace Business Park Pvt. Ltd.-SEZ (Formerly known as Serene Properties Pvt. Ltd.-SEZ), Mindspace, Thane-Belapur Road, Airoli, Navi Mumbai-400708** approved vide aforesaid letter of Approval No. for undertaking following authorized operations:

Name of Authorized Operations
Information Technology and Information Technology Enabled Services

16305  
16/06/17

We have started commercial operations w.e.f. 01.01.2015 from said unit.

**Other SEZ Units:** We have following other SEZ Units approved within your jurisdiction by your good office in SEEPZ-SEZ, Gigaplex-SEZ and Mindspace Business Park-SEZ:

S.No.	Nomenclature of the unit	Letter of Approval No. and date	Address of the unit
1	IPC 1	SEEPZ-SEZ/IA-I/APL/SW-01/2008-09/5761 Dated:	Unit No. 305-308, 3 <sup>rd</sup> Floor, Multistoried

HERE Solutions India Pvt. Ltd.

CIN: U72900MH2008FTC178295

19° 07' 32" N 72° 52' 30" E

Unit No. 305-308, 3rd Floor,  
Multistoried Building SEEPZ MIDC,  
Andheri-East, Mumbai - 400096

T+91 022 6607 9000  
F+91 022 6607 9001  
here.com

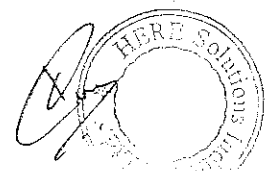

		07.08.2008 as amended	Building, SEEPZ-SEZ, MIDC, Andheri (E), Mumbai- 400096
2	IPC 2	SEEPZ/NEWSEZ/SERENE-THANE/12/2010-11/4636 Dated: 31.03.2011 as amended	Unit No. 1, 5 <sup>th</sup> Office Level, Building No. 5 & 6, Mindspace Business Park Pvt. Ltd.-SEZ (Formerly known as Serene Properties Pvt. Ltd.-SEZ), Mindspace, Thane-Belapur Road, Airoli, Navi Mumbai-400708
3	IPC 4	SEEPZ/NEW-SEZ/ Gigaplex- Thane/HSIPL/ 05/2015- 16/06471 Dated: 21.04.2016	3 <sup>rd</sup> Floor, Building No. 2, M/S Gigaplex Estate Pvt. Ltd.-SEZ, IT Plot No. 5, Airoli Knowledge Park, TTC Industrial Area, Airoli (W), Navi Mumbai- 400708
4	IPC 5	SEEPZ/NEW-SEZ/ Gigaplex- Thane/HSIPL/ 09/2016- 17/04356 Dated: 23.01.2017	4 <sup>th</sup> Floor, Building No. 2, IT Plot No. 5, M/S Gigaplex Estate Pvt. Ltd.-SEZ, Airoli Knowledge Park, TTC Industrial Area, Airoli (W), Navi Mumbai-400708

**Proposal:**

1. Since we have now 5 SEZ Units and in order to optimize the resources and to establish a highly secured/better communication channel for data transmission to our parent company/customers outside India, we wish to create a **Hub for communication purpose** in **IPC 3** location of ours, which will be accessed by/shared with all other IPCs i.e. **IPC 1, IPC 2, IPC 4 and IPC 5** location through primary circuits for data transmission purpose.

IPC 3 will in turn will have international circuits connected to one or more locations in either Europe or Asia Pacific (APAC) as primary circuits and secondary circuits to Non-SEZ Co-location in India for disaster recovery and BCP.

**Relevant Provisions:** Such creation and sharing of Infrastructure permission is sought in accordance with the provisions of Rule 27 (5) of SEZ Rules, 2006, which states as below:



***“A Unit may import or procure from Domestic Tariff Area, all types of goods and services, without payment of duty, taxes or cess for creating a central facility for use by Units in Special Economic Zone”.***

- 2. In order to terminate secondary circuit for connecting all these IPC locations and to have smooth flow of transactions in the event of any disaster either natural or manmade to keep continue exports from our units in order to generate valuable Foreign exchange to the country, we wish to obtain approval for Disaster Recovery (DR)/BCP (Business Continuity Plan) Centre outside SEZ.

**Relevant Provisions:** Such permission is sought in accordance with the Guidelines prescribed by Ministry of Commerce and Industry, New Delhi vide its letter No. D.12/25/2012-SEZ Dated: 22.02.2013 w.r.t. **“Setting up Disaster Recovery (DR) and Business Continuity Plans (BCP) Centers for IT/ITES SEZs.**

**Details of Proposed Creation and Sharing of Infrastructure at IPC 3 Location:**

As stated above, since we have now 5 SEZ units in Mumbai and Navi Mumbai area and in order to optimize the resources and to have Highly secured/better control on data transmission from our SEZ locations to outside India to our Parent company/customer, our management has decided to create **IPC 3 location** as a Hub for connecting all other IPC locations through Primary-circuit for data transmission purpose. In this scenario, we propose following to ensure 100% compliance as per SEZ Act and Rules:

- 1. Each IPC location i.e. **IPC 1, IPC 2, IPC 4 and IPC 5** will be connected to **IPC 3 location** through a primary circuit which will be terminated in **IPC 3**.
- 2. **IPC 3 Location** is then connected to International Circuits to one or more locations either in Europe or Asia Pacific (APAC) for transmitting all such data of **IPC 1, IPC 2, IPC 3, IPC 4 and IPC 5**. Further, **IPC 3 Location along with other IPC locations i.e. IPC 1, 2, 4 and 5** will also be connected to through secondary circuit to Non-SEZ Co-location for disaster recovery.
- 3. **IPC 3 Location** will create all requisite infrastructure including International leased lines and Networking equipment, which will be shared by other **IPC Locations on a cost sharing basis.**
- 4. **Safety and Security of Data:** Further, in order to ensure safety and security of data, each application is encrypted from the origin till final destination.

By virtue of which **data/information** pertains to one **IPC location** cannot be viewed or utilized by employees of other **IPC locations** and as a result **only authorized employees of particular IPC location** can access such data or information and can utilize the same for export of services.

- 5. **Purpose of Sharing:** The only purpose why we are proposing for creating and sharing of infrastructure is as below:



- (i) Optimization of resources in terms of creating single point infrastructure for carrying data traffic from India to outside India and thereby reduction of cost which is also a result of avoiding duplicate infrastructure set up at each IPC Location.
- (ii) Seamless connectivity and faster disaster recovery due to one primary circuit and one secondary circuit terminating at International Locations and Disaster Recovery/BCP Center respectively.
- (iii) Easy to maintain infrastructure due to central Hub at **IPC 3 location**.

6. **Internet Access:** Internet access for IPCs will be through our Internet exit point in **HERE** non-India location during both steady and failure state. This is a technical design requirement of **HERE** network, we cannot failover to a non-SEZ exit point in Mumbai as it would break the dataflows. While the Internet exit point outside India might change for number of reasons, such as failure in one **HERE** locations. In such cases, the dataflow for all **IPCs** would remain the same.

**Details of Proposed Disaster Recovery/BCP Center:**

As stated above, since **IPC 3** will act as Hub for all other IPCs and primary circuits from all other **IPCs** will be terminated into **IPC 3**. However, in the state of failure data will flow using secondary circuits terminated in proposed **Disaster Recovery/BCP Center located at:**

**Address of DR/BCP Center:**  
 Dhirubhai Ambani Knowledge Center,  
 Koparkhairne, Navi Mumbai

Detailed network diagram and dataflow will be as below:

1. **Network Diagram:** Network is such that Dataflow in steady state will always flow over the primary circuits and use international circuits from **IPC3**, which is represented by a **thick blue line** in the diagram.

**However**, during a circuit failure, traffic would automatically failover to secondary circuit and be forced out via one of the international circuits terminated in non-SEZ Co-Locations (DR/BCP Centers). In the diagram below, **IPC 1** has a red cross over the primary circuit indicating a circuit failure and dashed blue line showing the dataflow in such situation.

It is important to note that in steady state, when the primary circuit is up and operational, **IPC1** would follow the same dataflow as every other IPC depicted in the diagram.

2. Such DR/BCP location will be provided with adequate infrastructure including telecommunication links, administrative support system, data back up and retrieval systems as well.

**Detailed Dataflow diagram with various types of circuits is as below:**

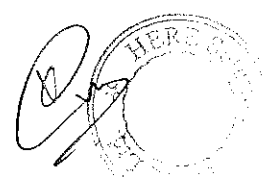

HERE India IPC WAN

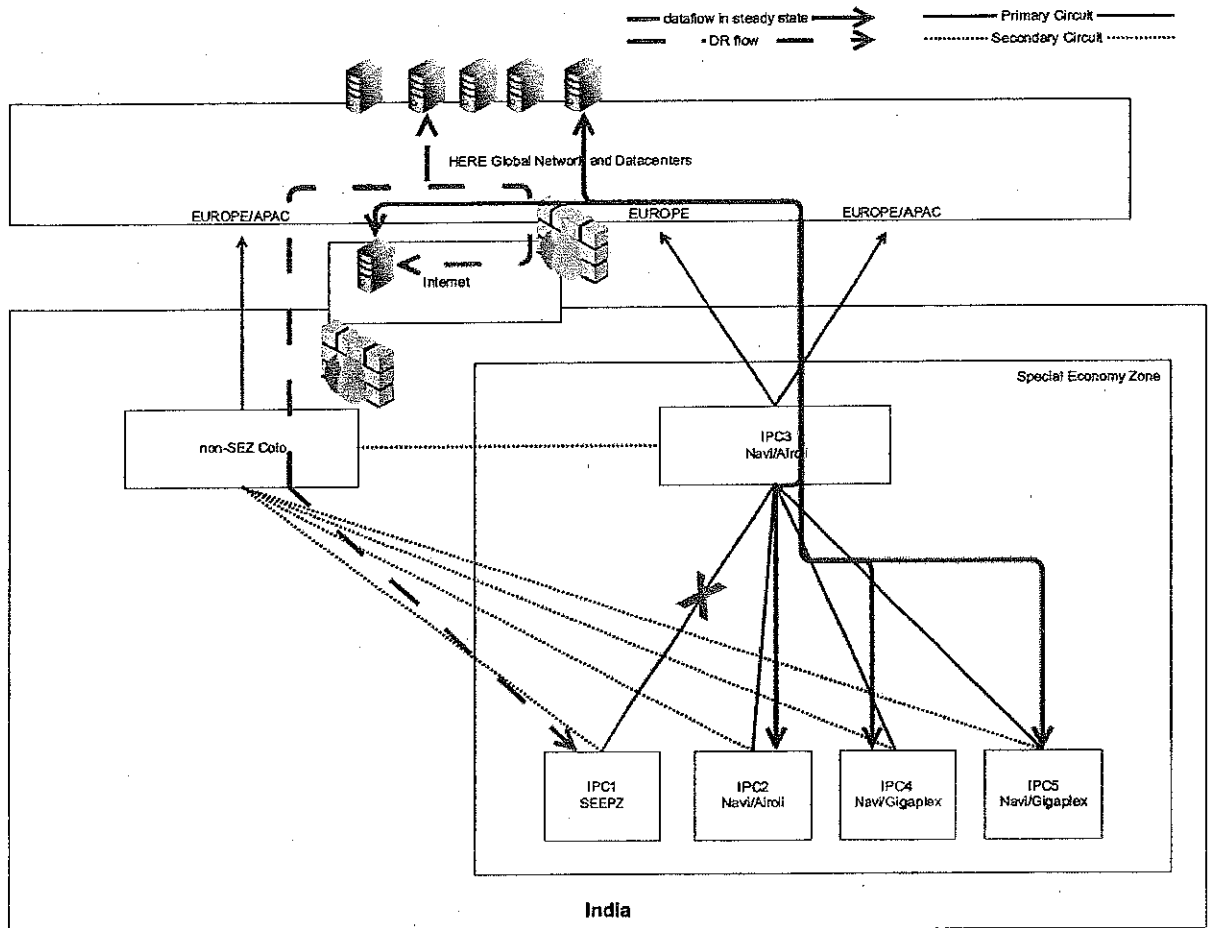

Following infrastructure facilities will be created by **IPC 3** and shall be shared by other IPCs i.e. IPC 1, IPC 2, IPC 4 and IPC 5.

S.No	Name of Infrastructure facility which will be shared
1	Routers
2	Other Networking Equipment's
3	Internet Lines/Private Circuits for receiving/transmitting data to International Circuits

Usage and Cost sharing:

Entire cost of creating the above mentioned common facilities is/will be incurred by **IPC 3** and has been/shall be recorded in the books/Bond register of **IPC 3** only, thus accordingly all benefits, exemptions etc has been/shall be availed by **IPC 3** for creating these common infrastructure facilities including equipment's required for that purpose.

*[Handwritten Signature]*  
 HERE SOLUTIONS  
 PVT. LTD.

325

In respect of sharing of the common infrastructure facility in terms of Network infrastructure and its equipment's, **IPC 3** shall recover an appropriate charge from other IPCs i.e. **IPC 1, IPC 2, IPC 4 and IPC 5** on cost sharing basis. Further, all SEZ units will use the aforesaid common infrastructure facilities for respective units authorized operations only.

**Approval Required:**

Considering the same, we would like to request your good office to grant us approval for following:

1. Creation and Sharing of common infrastructure facilities created by **IPC 3** location i.e. Network and its equipment as listed below with **other SEZ Units of ours i.e. IPC 1, IPC 2, IPC 4, IPC 5 in accordance to the provisions of Rule 27 (5) of SEZ Rules, 2006;**

S.No	Name of Infrastructure facility which will be shared
1	Routers
2	Networking Equipment's
3	Internet Lines/Private Circuits for receiving/transmitting data to International Circuits

2. Creation of Disaster Recovery/BCP Center for terminating secondary circuits for data communication purpose which will be used in the event of failure of Primary circuits and thereby pushing data from such DR/BCP Center to a location outside India in accordance to the **Guidelines Prescribed by Ministry of Commerce and Industry for setting up DR/BCP Centers vide its letter No. D.12/25/2012-SEZ Dated: 22.02.2013.**

We would also like to take reference from past UAC meeting, wherein such permissions were granted:

1. *“Approval for common Infrastructure facilities was being granted by UAC in case of Paternoster India Pvt Ltd and J.L.T. a SEZ units in Hiranandani IT/ITES-SEZ, Mumbai”.*
2. *Another precedent is for granting of common Infrastructure sharing approval in case of M/S Konecranes Shared Services India Pvt. Ltd. for their unit 1 and 2 in UAC meeting held for Magarpatta City-SEZ, dated: 19.06.2012.*

Should you require, any other information please feel free to revert to us.

Thanking you

For HERE Solutions India Pvt. Ltd. **IPC 3**

(Kiran Mahambre)  
(Manager - RECF)

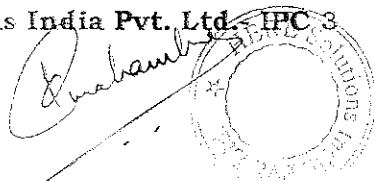



सत्यमेव जयते

243

भारत सरकार  
विकास आश्वासन का कर्षण  
सीपज़ विशेष आर्थिक क्षेत्र  
वाणिज्य और उद्योग मंत्रालय  
अंधेरी (पूर्व), मुंबई - 400 096.

GOVERNMENT OF INDIA  
Office of the Development Commissioner  
SEEPZ SPECIAL ECONOMIC ZONE  
Ministry of Commerce & Industry  
Andheri (East), Mumbai - 400 096.

9592

No. SEEPZ/NEW-SEZ/SERENE-THANE/43/2014-15 Dated: 24.07.2014

M/s. Here Solutions India Pvt. Ltd.

Unit No. 305- 308, (AC),  
Multistoried Building, SEEPZ-SEZ,  
Andheri (East),  
Mumbai - 400 096.

Sub: Your proposal for setting up a unit in Special Economic Zone.  
Ref.: Your application dated 16.06.2014 & 26.06.2014.

Sirs,

With reference to the above mentioned applications, Development Commissioner, SEEPZ Special Economic Zone is pleased to extend to you all the facilities and entitlements admissible to a unit in a Special Economic Zone subject to the provisions of the Special Economic Zones Act, 2005 and the rules and orders made there-under and for the establishment of a unit at located at Unit No. - 1, 3<sup>rd</sup> Office Level, Building No. 5 & 6, Serene Properties Pvt. Ltd. - SEZ, Mindspace, Thane - Belapur Road, Airoli, Navi Mumbai - 400 708 in the State of Maharashtra for undertaking authorized operations as under:-

<b>Authorized Operations : Manufacturing/Service Activities</b>
Information Technology & Information Technology Enabled Services.

2. This approval is subject to following terms and conditions:

- (i) You shall export the goods manufactured/services as per provisions of the Special Economic Zones Act, 2005 and Rules made there-under for a period of five years from the date of commencement of production activities. For this purpose, you shall execute the Bond-cum-Legal Undertaking as prescribed under the Special Economic Zone Rules, 2006.

Contd.....2/-

दूरभाष : 26290146 / 26292144  
Telephone : 26290146 / 26292147

E-mail : dcssez@seepz.gov.in  
Website : www.seepz.gov.in

दूरभाष : 26291754 / 26291754  
Fax : 26291754 / 26291754

विकास (विशेष) आर्थिक क्षेत्रों के अंतर्गत - वाणिज्य और उद्योग मंत्रालय

- (ii) You shall fulfill the pollution control requirements, as may be prescribed by the Pollution Control authorities.
- (iii) You shall achieve positive Net Foreign Exchange (NFE) as prescribed in the Special Economic Zone Rules, 2006 for the period you operate as a Unit in the Special Economic Zone from the commencement of production, failing which you shall be liable for penal action under the Foreign Trade (Development and Regulation) Act, 1992.
- (iv) Procurement of second hand capital goods shall be allowed only in terms of provisions of sub-section (4) of Section 10AA read with Explanation 1 & 2 to sub-section (3) of Section 80IA of Income Tax Act, 1961. The procedure prescribed in Instruction No. 11 dated 12.08.2009 issued by Ministry of Commerce & Industry would have to be followed in this regard.
- (v) You may import or procure from the Domestic Tariff Area all the items (other than (iv) above) required for your authorized operations under this approval, except those prohibited under the ITC (HS) Classifications of Export and Import items.
- (vi) You may supply/sell goods in the Domestic Tariff Area in terms of the provisions of the Special Economic Zones Act 2005 and rules and orders made there-under.
- (vii) This Letter of Approval is valid for a period of one year from its date of issue. You shall implement the project and commence production within **One year** period or within such period as may be extended.
- (viii) Date of commencement of production shall be intimated to the Development Commissioner, SEEPZ SEZ.
- (ix) ~~The lease period of space allotted shall not be less than five years but not withstanding any other condition in the lease deed, the lease rights would cease to exist in case of the expiry or cancellation of the Letter of Approval.~~
- (x) This Letter of Approval shall be valid for a period of five years from the date of commencement of production.
- (xi) The approval is based on the details furnished by you in your proposal/application.
- (xii) You shall abide by the provisions of Special Economic Zones Act, 2005 and the rules and orders made there-under.

Contd.....3/-



- (xxv) In terms Rule 11 (5) of the SEZ Rules, 2006, the lease period shall not be less than 5 years and in terms of Proviso to Rule 18 (2) of the SEZ Rules, 2006, a copy of registered lease deed shall be furnished within 6 months from issuance of the Letter of Approval.
- (xxvi) You have the option to renew the approval or exit in terms of the provisions of the Special Economic Zones Act, 2005 and the rules and orders made there-under.
- (xxvii) You shall confirm acceptance of the above terms and condition to the Development Commissioner within forty-five days of issue of this Letter of Approval.
- (xxviii) If you fail to comply with the conditions stipulated above, this Letter of Approval shall be cancelled as per the provisions of the Special Economic Zones Act, 2005 and the rules and orders made there-under.
- (xxix) All future correspondence including for amendments / changes in terms and conditions of the Letter of Approval or for extension of its validity shall be addressed to the Development Commissioner.
- (xxx) Hindi version follows.

Yours faithfully,



**(P. S. Raman)**  
Joint Development Commissioner  
SEEPZ-SEZ